

Model 31 High

High Range Precision Miniature Load Cell

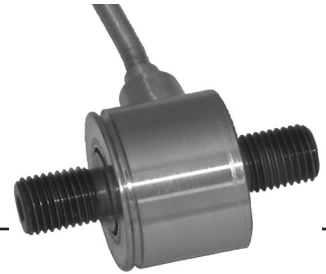

DESCRIPTION

Model 31 high range precision miniature load cells measure both tension and compression load forces of 2000 lb to 10000 lb. These models are our highest accuracy, rugged miniature load cells. Model 31's welded, stainless steel construction is designed to eliminate or reduce to a minimum, the effects of off-axis loads. (The internal construction assures excellent long-

term stability for ranges 1000 grams and above.) A modification permits this model to be completely welded for underwater applications. The Model 31 tension/compression load cell has male threads attachments. High accuracies of 0.15 % to 0.25 % full scale are achieved. Each bonded strain gage unit is built of welded 17-4 PH stainless steel for additional ruggedness.

FEATURES

- 2000 lb to 10000 lb
- mV/V output
- Stainless steel
- Miniature design
- Stabilized column construction

Model 31 High

PERFORMANCE SPECIFICATIONS

Characteristic	Measure
Load ranges ⁵	2000 lb to 10000 lb
Linearity	±0.2 % full scale
Hysteresis	±0.2 % full scale
Non-repeatability	±0.05 % full scale
Tolerance on output	2 mV/V
Operation	Tension/compression ³
Resolution	Infinite

ENVIRONMENTAL SPECIFICATIONS

Characteristic	Measure
Temperature, operating	-53 °C to 121 °C [-65 °F to 250 °F]
Temperature, compensated	15 °C to 71 °C [60 °F to 160 °F]
Storage temperature	-73 °C to 148 °C [-100 °F to 300 °F]
Temperature effect, zero	0.005 % full scale/°F
Temperature effect, span	0.005 % full scale/°F

ELECTRICAL SPECIFICATIONS

Characteristic	Measure
Strain gage type	Bonded foil
Excitation (calibration)	5 Vdc
Insulation resistance	5000 Mohm @ 50 Vdc
Bridge resistance	350 ohm
Zero balance	1 % max.
Electrical termination (std)	Teflon cable (1524 mm [60 in])

MECHANICAL SPECIFICATIONS

Characteristic	Measure
Maximum allowable load	150 % FS ¹
Weight	See table
Material	17-4 PH stainless steel
Deflection full scale	See table
Natural frequency	See table

WIRING CODES

Cable	Unamplified
Red	(+) excitation
Black	(-) excitation
Green	(-) output
White	(+) output

RANGE CODES

Range codes	Range
DL	2000 lb
DN	3000 lb
DP	4000 lb
DR	5000 lb
DT	7500 lb
DV	10000 lb

DEFLECTIONS AND RINGING FREQUENCIES

Capacity (lb)	Deflection at full scale	Ringling frequency	Weight
2000 lb, 3000 lb	0.03 mm [0.001 in]	26000 Hz	60 g
4000 lb, 5000 lb	0.04 mm [0.0015 in]	21000 Hz	125 g
7500 lb, 10000 lb	0.04 mm [0.0015 in]	17000 Hz	250 g

High Range Precision Miniature Load Cell

MOUNTING DIMENSIONS

Ranges (lb)	T	ØD	C	H
2000 lb, 3000 lb	3/8-24 UNF	25,4 mm [1.00 in]	12,7 mm [0.50 in]	18,29 mm [0.72 in]
4000 lb, 5000 lb	1/2-20 UNF	31,75 mm [1.25 in]	16 mm [0.63 in]	23,88 mm [0.94 in]
7500 lb, 10000 lb	3/4-16 UNF	35,05 mm [1.38 in]	22,35 mm [0.88 in]	27,94 mm [1.10 in]

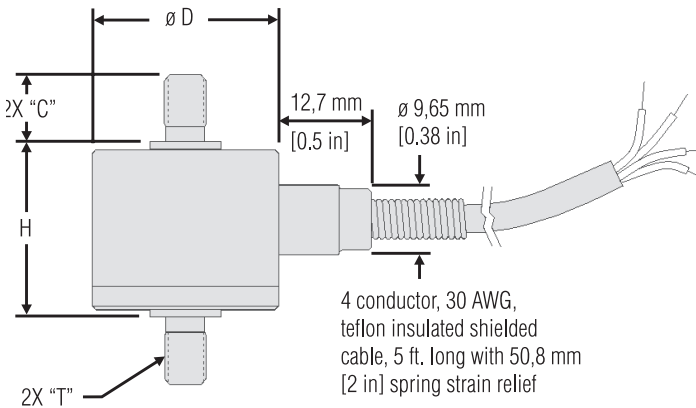

OPTION CODES

	Many range/option combinations are available in our quick-ship and fast-track manufacture programs. Please see http://sensing.honeywell.com/TMsensor-ship for updated listings.	
Load range	2000 lb, 3000 lb, 4000 lb, 5000 lb, 7500 lb, 10000 lb	
Temperature compensation	1a. 60 °F to 160 °F 1b. 30 °F to 130 °F 1c. 0 °F to 185 °F 1d. -20 °F to 130 °F 1e. -20 °F to 200 °F 1f. 70 °F to 250 °F	1g. 70 °F to 325 °F 1h. 70 °F to 400 °F 1i. -65 °F to 250 °F 1j. 0 °C to 50 °C 1k. -20 °C to 85 °C 1m. -25 ° to 110 °C
Internal amplifiers	2u. Unamplified, mV/V output	
Electrical termination	6e. Integral cable: Teflon 6d. Microtec DR-4S-4H 4 pin 6f. Integral cable: PVC 6g. Integral cable: Neoprene (max. 180 °F)	6h. Integral cable: Silicone 6i. Integral underwater cable (max. 180 °F) 6v. Phoenix connector on end of cable
Bridge resistance	12a. 1000 ohm (foil) 12b. 5000 ohm (foil)	
Electrical connector orientation	15a. Horizontal electrical exit port orientation 15b. Vertical electrical exit port orientation 15c. Radial electrical exit port orientation 15d. Connector on end of cable	
Special calibration	30a. Compression only calibration, positive in compression 30b. Tension and compression calibration, positive in tension 30c. Compression only calibration, negative in compression 30d. Tension and compression calibration, positive in compression	
Shock and vibration	44a. Shock and vibration resistance	
Interfaces	53e. Signature calibration ⁶ 53t. TEDS IEEE 1451.4 module ⁴	

Model 31 High

High Range Precision Miniature Load Cell

NOTES

1. Allowable maximum loads - maximum load to be applied without damage. ²
2. Without damage - loading to this level will not cause excessive zero shift or performance degradation. The user must consider fatigue life for long term use and structural integrity. All structurally critical applications (overhead loading, etc.) should always be designed with safety redundant load paths.
3. Standard calibration for tension/compression load cells is in tension only.
4. TEDS available with integral cable units only.
5. This unit calibrated to Imperial (non-Metric) units.
6. Signature calibration only available as inline module.

TYPICAL SYSTEM DIAGRAM

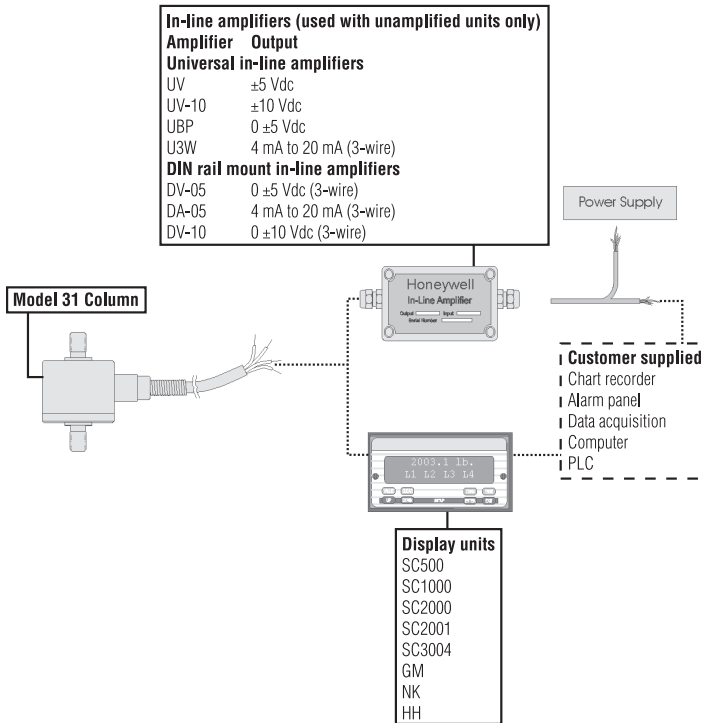

Warranty. Honeywell warrants goods of its manufacture as being free of defective materials and faulty workmanship. Honeywell's standard product warranty applies unless agreed to otherwise by Honeywell in writing; please refer to your order acknowledgement or consult your local sales office for specific warranty details. If warranted goods are returned to Honeywell during the period of coverage, Honeywell will repair or replace, at its option, without charge those items it finds defective. **The foregoing is buyer's sole remedy and is in lieu of all warranties, expressed or implied, including those of merchantability and fitness for a particular purpose. In no event shall Honeywell be liable for consequential, special, or indirect damages.**

While we provide application assistance personally, through our literature and the Honeywell web site, it is up to the customer to determine the suitability of the product in the application.

Specifications may change without notice. The information we supply is believed to be accurate and reliable as of this printing. However, we assume no responsibility for its use.

For more information about Sensing and Control products, visit www.honeywell.com/sensing or call +1-815-235-6847
Email inquiries to info.sc@honeywell.com

⚠ WARNING PERSONAL INJURY

- DO NOT USE these products as safety or emergency stop devices or in any other application where failure of the product could result in personal injury.

Failure to comply with these instructions could result in death or serious injury.

⚠ WARNING MISUSE OF DOCUMENTATION

- The information presented in this catalogue is for reference only. DO NOT USE this document as product installation information.
- Complete installation, operation and maintenance information is provided in the instructions supplied with each product.

Failure to comply with these instructions could result in death or serious injury.

Sensing and Control
Automation and Control Solutions
Honeywell
1985 Douglas Drive North
Golden Valley, MN 55422 USA
+1-815-235-6847
www.honeywell.com/sensing

008631-1-EN IL50 GLO
May 2008
Copyright © 2008 Honeywell International Inc. All rights reserved.

Honeywell