

## Model 425

## Wing Union Pressure Transmitter



### DESCRIPTION

The Model 425 Wing Union Pressure Transmitters are rugged sensors designed for use with 1502 and 2202 wing unions in demanding land-based and off-shore applications.

The isolated pressure sensing diaphragm minimizes zero shift during hammer-up and eliminates long-term signal drift in the field. The sensor diaphragm and wing union fitting are machined as one part. The Model 425 is constructed as an all-welded assembly using a deep penetration, proprietary, electron beam

welding process which also ensures hermetic integrity for all field conditions. These transmitters incorporate special assembly processes to vibration and shock proof the components to ensure performance is maintained during the rigors of fracturing and cementing applications. The 1502 and 2202 wing union compatible fittings are machined of Inconel X-750 providing service with highly abrasive and corrosive media. Both configurations comply with NACE Standard MR-01-75 (1980) for corrosive service.

### FEATURES

- Quick delivery service
- Long life X-750 material
- Rugged, robust design
- RFI/EMI protected
- 0.2 % accuracy
- Optional on-board temperature sensor
- Intrinsically safe
- CE approved

# Model 425

## PERFORMANCE SPECIFICATIONS

Characteristic	Measure
Pressure ranges	0 psi to 5000 psi; 0 psi to 6000 psi; 0 psi to 10000 psi; 0 psi to 15000 psi; 0 psi to 20000 psi <sup>3</sup>
Accuracy <sup>1</sup>	±0.2 % best fit straight line
Calibration	5-point calibration: 0 %, 50 %, and 100 % of full scale
Output	4 mA to 20 mA, two-wire
Resolution	Infinite

## ENVIRONMENTAL SPECIFICATIONS

Characteristic	Measure
Temperature, operating	-43 °C to 93 °C [-45 °F to 200 °F]
Temperature, compensating	-34 °C to 82 °C [-30 °F to 180 °F]
Temperature effect, zero	0.018 % full scale/°C [0.01 % full scale/°F]
Temperature effect, span	0.018 % reading/°C [0.01 % reading/°F]
Temperature effect, sealing	Hermetically sealed IP68/NEMA 6P

## ELECTRICAL SPECIFICATIONS

Characteristic	Measure
Supply voltage	9 Vdc to 28 Vdc
Insulation resistance	>100 MΩ @ 50 Vdc
Max. loop resistance	950 ohm @ 28 V decreasing linearly to 0 ohm @ 9 V
Circuit protection	Reverse polarity protection of supply leads
RFI/EMI protection	Noise immunity from 5000 Hz to 1 GHz
Frequency response	Customer specified and factory installed filter for frequency response of min. 10 Hz to max. of 2500 Hz
Zero and span adjustment	Field adjustable by removing connector
Shunt calibration data	Included
Electrical termination (std)	MS-3102E-14S-2P, 4-pin stainless steel hermetic equal

## MECHANICAL SPECIFICATIONS

Characteristic	Measure
Media	Corrosive and abrasive service, Inconel X-750
Overload, safe	150 % rated full scale pressure or limit of wing union 1502 fitting
Overload, burst	250 % rated pressure or limit of wing union 1502 fitting
Pressure port	1502 wing union, 51 mm [2 in] pipe, male sub end
Wetted parts material	Inconel X-750
Weight	2722 g [6 lb]
Case material	Inconel X-750 (labels are welded stainless steel with embossed characters)

## RANGE CODES

Range Code	Available ranges
<b>DR</b>	0 psi to 5000 psi
<b>DS</b>	0 psi to 6000 psi
<b>DV</b>	0 psi to 10000 psi
<b>EJ</b>	0 psi to 15000 psi
<b>EL</b>	0 psi to 20000 psi <sup>3</sup>

## WIRING CODES

	Amp (NS), 3-cond, 4 pin, ground
A	No connection
B	(+) Output
C	(+) Supply
D	Case ground

# Wing Union Pressure Transmitter

## INTERNAL AMPLIFIERS

Amplifier specifications	Intrinsically safe amp: Option 2n(2N)***
Output signal	4 mA to 20 mA
Input power (voltage)	9 Vdc to 28 Vdc
Input power (current)	4 mA to 24 mA
Frequency response (amp)	2500 Hz
Power supply rejection	60 db
Operating temperature	-43 °C to 93 °C [-45 °F to 200 °F]
Reverse voltage protection	Yes
Short circuit protection	Yes
Wiring code: connector (std)	A No connection B (+) Output C (+) Supply D Case ground

\*\*\* See Honeywell's Web site for the most up-to-date information regarding intrinsically safe approvals, ref. #008-0547-00.

## OPTION CODES

Range Code	Many range/option combinations are available in our quick-ship and fast-track manufacture programs. Please see <a href="http://sensing.honeywell.com/TMsensor-ship">http://sensing.honeywell.com/TMsensor-ship</a> for updated listings.
Pressure ranges <sup>3</sup>	0 psi to 5000 psi; 0 psi to 6000 psi; 0 psi to 10000 psi; 0 psi to 15000 psi; 0 psi to 20000 psi
Temperature compensation	-34 °C to 82 °C [-30 °F to 180 °F]
Internal amplifiers	2n(2N). 4 mA to 20 mA, two-wire output; intrinsically safe
Electrical termination	MS-3102E-14S-2P, 4 pin stainless steel hermetic 6a. Bendix PTIH-10-6P (or equivalent) 6 pin (max. 121 °C [250 °F])
Shunt calibration	3d. Remote buffered shunt calibration
Special calibration <sup>2</sup>	9a. 10 point (5 up/5 down) 20 % increments @ 21 °C [70 °F] 9b. 20 point (10 up/10 down) 10 % increments @ 21 °C [70 °F]
Wetted diaphragm	10e. Inconel X-750
Zero and span adjustment	14b. Top access to pots
Temperature sensing options	45c. RTD output direct to connector. Gives temperature as a resistance reading. Intrinsically safe 45d. RTD with temperature as a 4 mA to 20 mA output. Not intrinsically safe.

## TYPICAL SYSTEM DIAGRAM

See <http://sensing.honeywell.com/TMsensor-help> for system information.

## MOUNTING DIMENSIONS

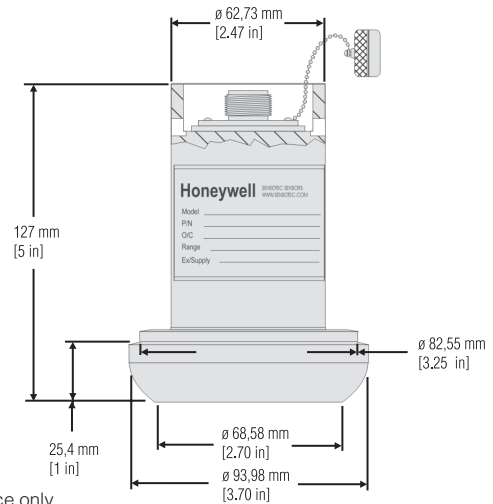

For reference only



## SPECIAL REQUIREMENTS (CONSULT FACTORY)

Have a special requirement? New case pressure, different cable lengths, electrical connectors, or materials? Consult our factory by calling +1 614-850-5000 (800-848-6564). Customization is key to our test and measurement business. Special outputs, wiring codes, and calibrations are all standard to us.

# Model 425

# Wing Union Pressure Transmitter

## NOTES

1. Accuracies stated are expected for best fit straight line for all errors including linearity, hysteresis and non-repeatability thru zero.
2. Availability varies with range.
3. Working pressure and approval limited to 15000 psi. Amplifier will allow overpressure readings to 20000 psi.

**Warranty.** Honeywell warrants goods of its manufacture as being free of defective materials and faulty workmanship. Honeywell's standard product warranty applies unless agreed to otherwise by Honeywell in writing; please refer to your order acknowledgement or consult your local sales office for specific warranty details. If warranted goods are returned to Honeywell during the period of coverage, Honeywell will repair or replace, at its option, without charge those items it finds defective. **The foregoing is buyer's sole remedy and is in lieu of all warranties, expressed or implied, including those of merchantability and fitness for a particular purpose. In no event shall Honeywell be liable for consequential, special, or indirect damages.**

While we provide application assistance personally, through our literature and the Honeywell web site, it is up to the customer to determine the suitability of the product in the application.

Specifications may change without notice. The information we supply is believed to be accurate and reliable as of this printing. However, we assume no responsibility for its use.

For more information about Sensing and Control products, visit [www.honeywell.com/sensing](http://www.honeywell.com/sensing) or call +1-815-235-6847

Email inquiries to [info.sc@honeywell.com](mailto:info.sc@honeywell.com)

### **WARNING** **PERSONAL INJURY**

- DO NOT USE these products as safety or emergency stop devices or in any other application where failure of the product could result in personal injury.

**Failure to comply with these instructions could result in death or serious injury.**

### **WARNING** **MISUSE OF DOCUMENTATION**

- The information presented in this catalogue is for reference only. DO NOT USE this document as product installation information.
- Complete installation, operation and maintenance information is provided in the instructions supplied with each product.

**Failure to comply with these instructions could result in death or serious injury.**

Sensing and Control  
Automation and Control Solutions  
Honeywell  
1985 Douglas Drive North  
Golden Valley, MN 55422 USA  
+1-815-235-6847  
[www.honeywell.com/sensing](http://www.honeywell.com/sensing)

008682-1-EN IL50 GLO  
May 2008  
Copyright © 2008 Honeywell International Inc. All rights reserved.

# Honeywell